



**SMONTAGOMME SUPERAUTOMATICO  
A DUE VELOCITÀ  
TWO SPEED TILT-BACK TYRE CHANGER  
DEMONTE-PNEUS SUPER-AUTOMATIQUE  
A DEUX VITESSES**



**S 224**



**DATI  
TECNICI****STANDARD  
FEATURES****DONNEES  
TECHNIQUES****TECHNISCHE  
ANGABEN****DATOS  
TÉCNICOS****S 224**

Bloccaggio cerchio	Rim clamping	Blocage jante	Felgeneinspannung	Bloqueo llanta	10" - 24"
Diametro max.ruota	Max.wheel diameter	Diamètre maxi.roue	Max.Raddurchmesser	Diámetro máx. rueda	1000 mm (39")
Largh. max. ruota	Max.wheel width	Largeur maxi.roue	Max.Radbreite	Ancho máx. rueda	385 mm (15")
Forza max. cilindro stallonatore	Max. bead-loosener cylinder force	Force vérin décolleur maxi.	Max. Kraft des Wulstabdrückzylinders	Fuerza máx. cilindro destalonador	30800 N
Pressione d'esercizio	Operating pressure	Pression de service	Betriebsdruck	Presión de trabajo	10 bar (145 psi)
Velocità di rotazione	Rotating speed	Vitesse de rotation	Drehgeschwindigkeit	Velocidad de rotación	7-14 rpm
Alimentazione	Power supply	Alimentation	Stromzufuhr	Alimentación	400 V 3ph
Potenza motore	Motor power	Puissance moteur	Motorleistung	Potencia motor	0,8-1,1 kW
Coppia max. mandrino	Max. spindle torque	Couple maxi.mandrin	Maximales Kräftepaar an der Hauptspindel	Par máx. de mandril	1200 Nm
Limitatore pressione gonfiaggio max.	Inflating pressure limiting device max.	Dispositif limiteur de pression de gonflage maxi.	Vorrichtung zur Reifenfülldruckbegrenzung max.	Dispositivo limitador de presión de inflado máx.	3,5 bar (50 psi)
Peso netto	Net weight	Poids net	Nettogewicht	Peso neto	244 kg STD 264 kg GT

Other voltages available upon demand

The specifications stated on this brochure are not binding. Giuliano S.p.A. reserves the right to change any specification without notice.

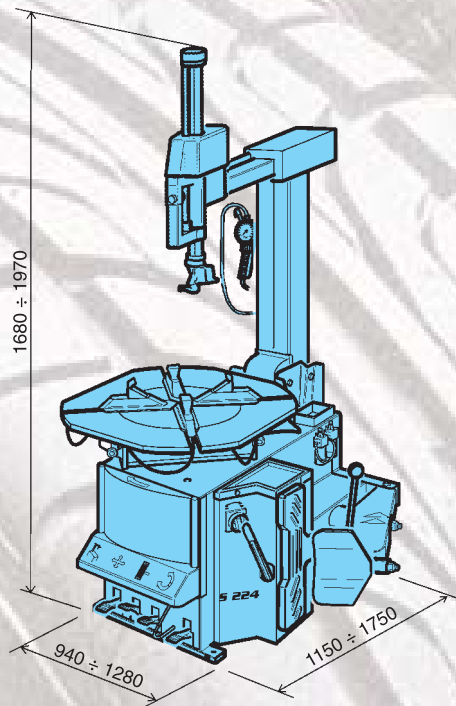
**STANDARD ACCESSORIES****S 224**

TYRE-CHANGERS



WHEEL-BALANCERS



WHEEL ALIGNMENT



LIFTS



TESTING EQUIPMENT



GIULIANO S.p.A. : Via Guerrieri, 6 - 42015 CORREGGIO (RE) ITALY  
Tel. +39 0522 731111 - Telefax +39 0522 633109 - E-mail: giuliano@giuliano.it - Internet : www.giuliano.it



05/2007